

TRIM AND FRAMING DETAIL

DIMENSIONS ARE THE SAME FOR ALL TRIM AND PANEL PIECES

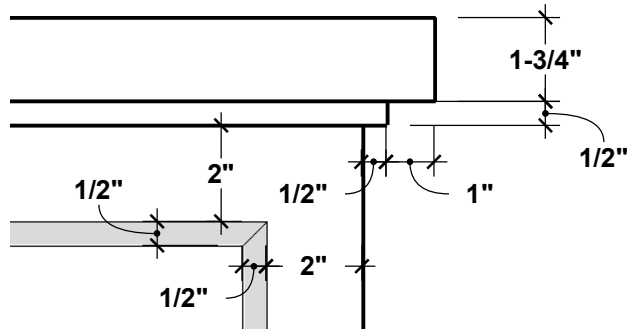

PERSPECTIVE VIEW

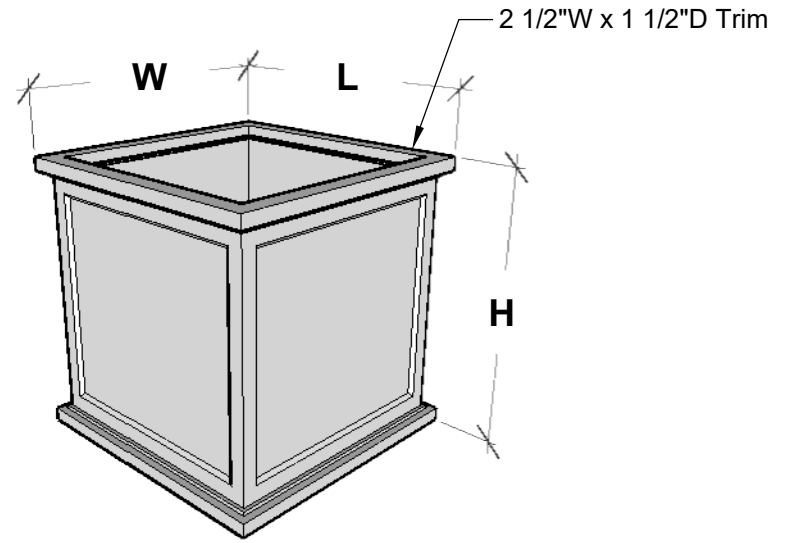

BOTTOM VIEW

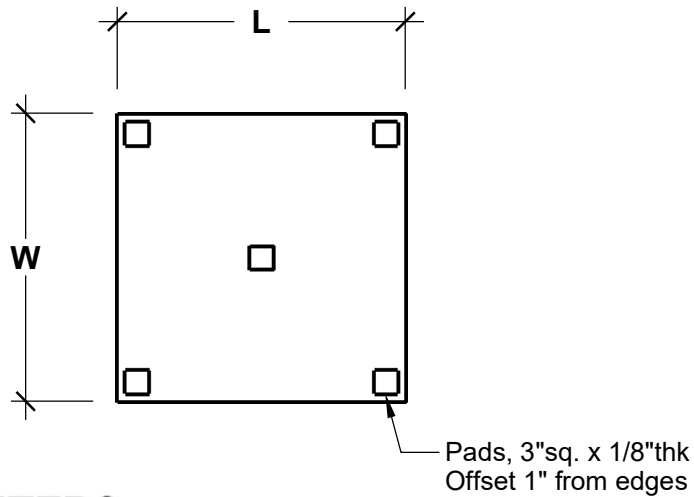

FRONT VIEW

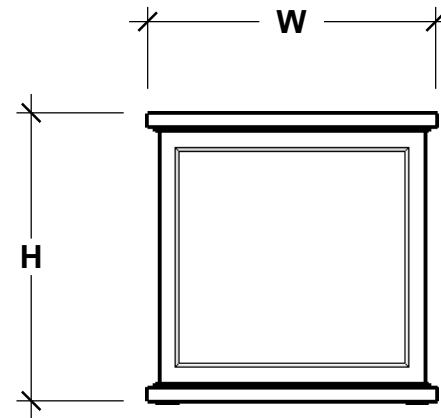

PLANTERS
UNLIMITED

A Carlsbad Manufacturing Company

1 (888) 320-0626

www.plantersunlimited.com

GENERAL NOTES

STANDARD DRAINAGE: YES NO

Internal Stiffeners as needed

PRODUCT DESCRIPTION				SKU				PREPARED FOR		APPROVAL SIGNATURE
KESWICK PLANTER				F1-KES-S				-		
DIMENSIONS	MATERIAL	COLOR / FINISH	REP	DB	DATE	REV	ORDER #	PROJECT / SIDEMARK / IF#	APPROVAL DATE	
-	Fiberglass	-	-	IG	10/21/2024	1	-			

PLEASE NOTE: Due to the handmade nature of our products, individual measurements may vary from those listed. The provided dimensions are for reference only

All images are the intellectual property of Planters Unlimited. Reproduction in any form is strictly prohibitive without the express written permission of Planters Unlimited. All designs are property of Planters Unlimited.