

FRONT VIEW

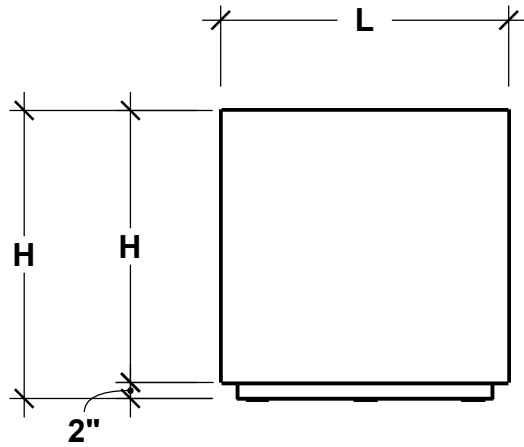

PERSPECTIVE VIEW

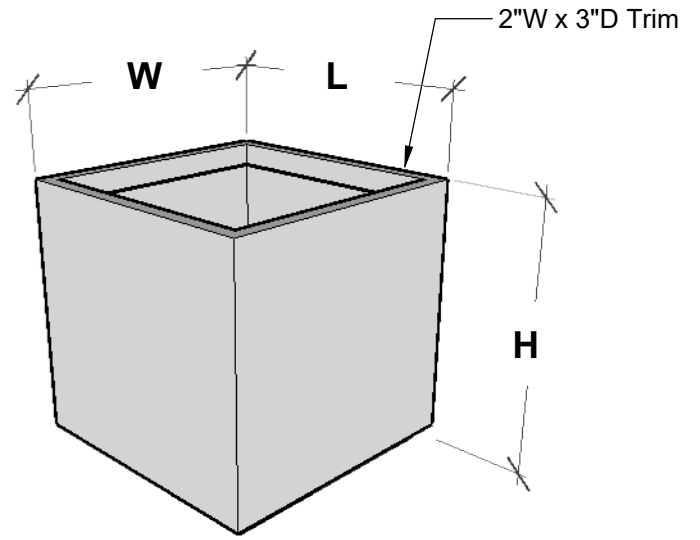

BOTTOM VIEW

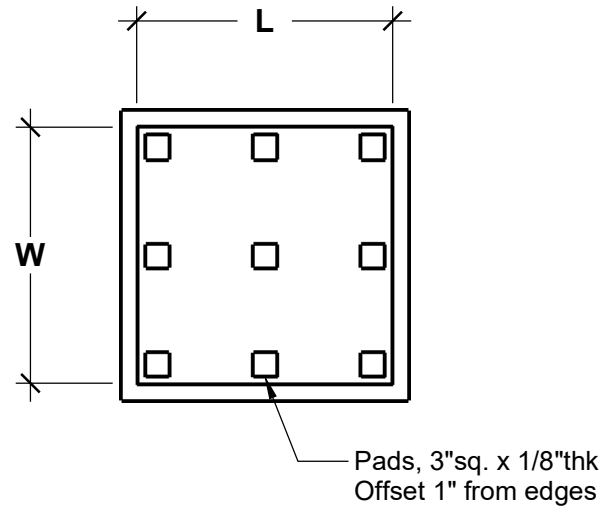

TOP VIEW

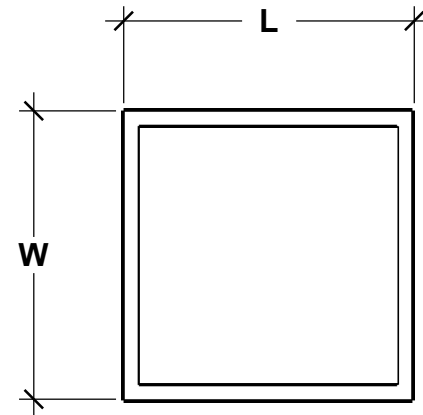

PLANTERS
UNLIMITED

A Carlsbad Manufacturing Company

1 (888) 320-0626

www.plantersunlimited.com

GENERAL NOTES

STANDARD DRAINAGE: YES NO

Internal Stiffeners as needed

| PRODUCT DESCRIPTION | | | | SKU | | | | PREPARED FOR | | APPROVAL SIGNATURE |
|----------------------|------------|----------------|-----|----------|------------|-----|---------|--------------------------|---------------|--------------------|
| MAREK SQUARE PLANTER | | | | F1-MAR-S | | | | - | | |
| DIMENSIONS | MATERIAL | COLOR / FINISH | REP | DB | DATE | REV | ORDER # | PROJECT / SIDEMARK / IF# | APPROVAL DATE | |
| - | Fiberglass | - | - | IG | 10/21/2024 | 1 | - | | | |

PLEASE NOTE: Due to the handmade nature of our products, individual measurements may vary from those listed. The provided dimensions are for reference only

All images are the intellectual property of Planters Unlimited. Reproduction in any form is strictly prohibitive without the express written permission of Planters Unlimited. All designs are property of Planters Unlimited.