

TOP VIEW

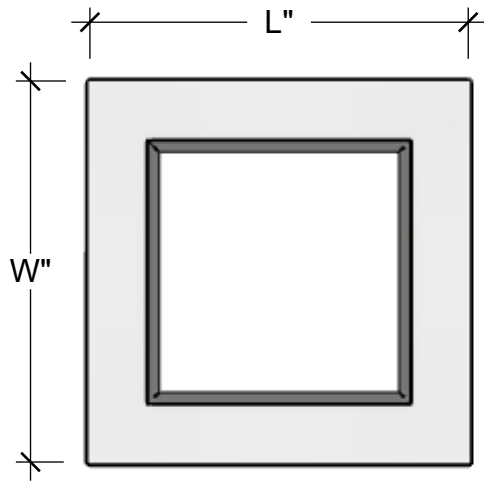

PERSPECTIVE VIEW

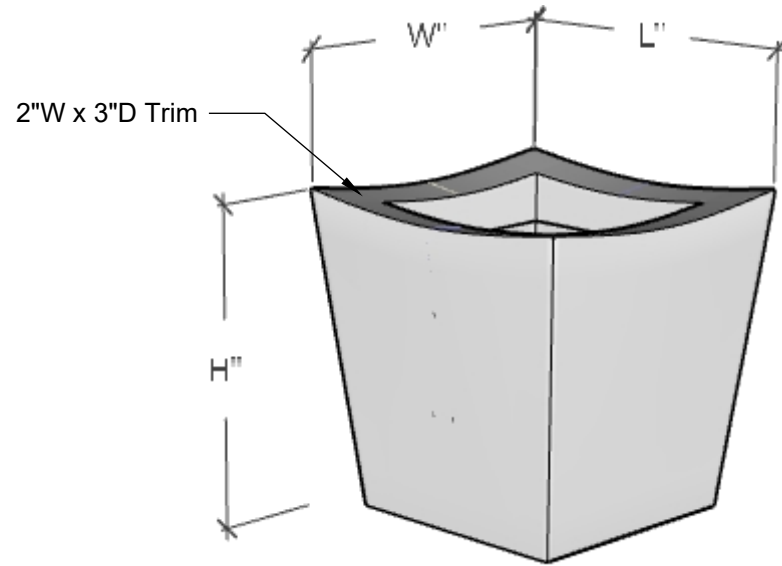

BOTTOM VIEW

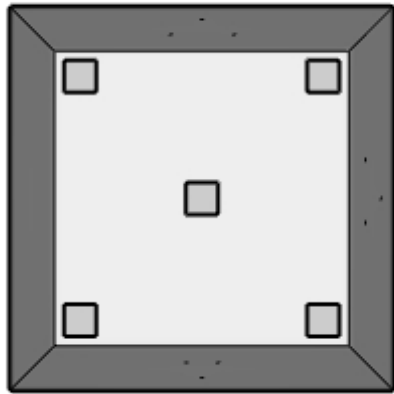

SIDE VIEW

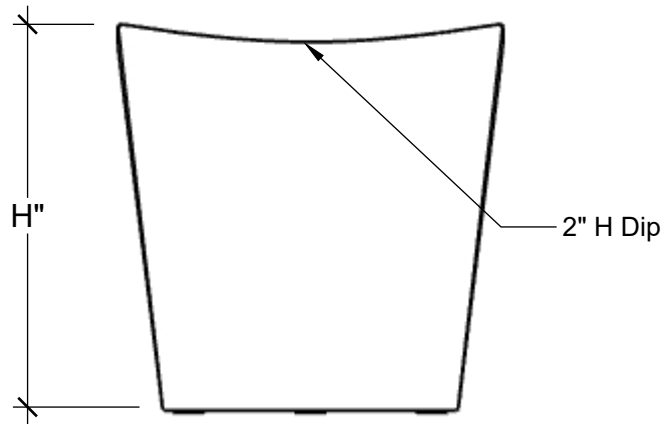

GENERAL NOTES

STANDARD DRAINAGE: YES NO

PLANTERS
UNLIMITED

A Carlsbad Manufacturing Company

1 (888) 320-0626

www.plantersunlimited.com

PRODUCT DESCRIPTION				SKU				PREPARED FOR		APPROVAL SIGNATURE
NAZCA SQUARE PLANTER				F1-NAZ-S						
DIMENSIONS	MATERIAL	COLOR / FINISH	REP	DB	DATE	REV	ORDER #	PROJECT / SIDEMARK / IF#	APPROVAL DATE	
	FIBERGLASS		Daniel	RM	10/2024					

PLEASE NOTE: Due to the handmade nature of our products, individual measurements may vary from those listed. The provided dimensions are for reference only

All images are the intellectual property of Planters Unlimited. Reproduction in any form is strictly prohibitive without the express written permission of Planters Unlimited. All designs are property of Planters Unlimited.