

TOP VIEW

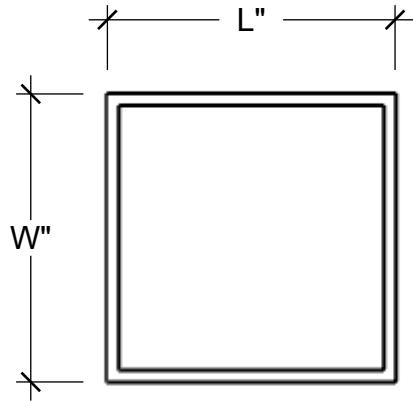

PERSPECTIVE VIEW

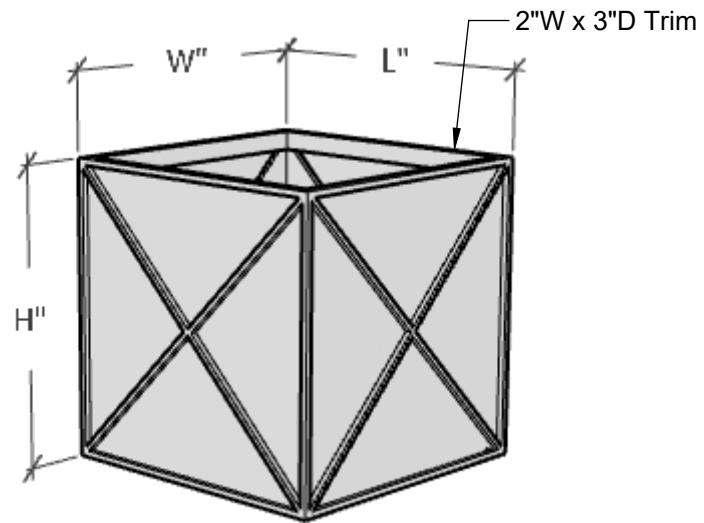

BOTTOM VIEW

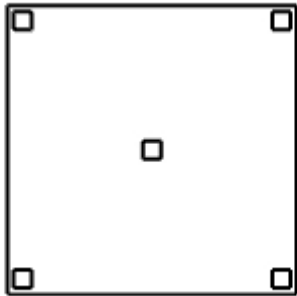

SIDE VIEW

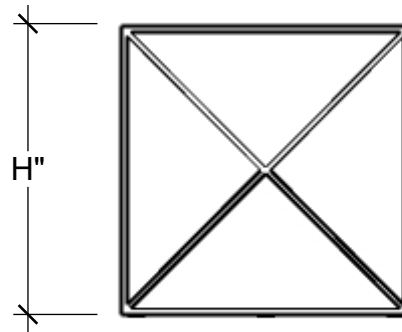

PLANTERS
UNLIMITED

A Carlsbad Manufacturing Company

1 (888) 320-0626

www.plantersunlimited.com

GENERAL NOTES

STANDARD DRAINAGE: YES NO

PRODUCT DESCRIPTION				SKU				PREPARED FOR	APPROVAL SIGNATURE
XANDER SQUARE PLANTER				F1-XAN-S					
DIMENSIONS	MATERIAL	COLOR / FINISH	REP	DB	DATE	REV	ORDER #	PROJECT / SIDEMARK / IF#	APPROVAL DATE
	FIBERGLASS		Daniel	RM	10/2024				

PLEASE NOTE: Due to the handmade nature of our products, individual measurements may vary from those listed. The provided dimensions are for reference only. All images are the intellectual property of Planters Unlimited. Reproduction in any form is strictly prohibitive without the express written permission of Planters Unlimited. All designs are property of Planters Unlimited.